



[www.fantasiaweb.it](http://www.fantasiaweb.it)



# Campagna per la salute scolastica

A CURA DI VINCENZO RICCIO

SAPER PARLARE SAPER LEGGERE SAPER SCRIVERE



# Stai lavorando a questo livello

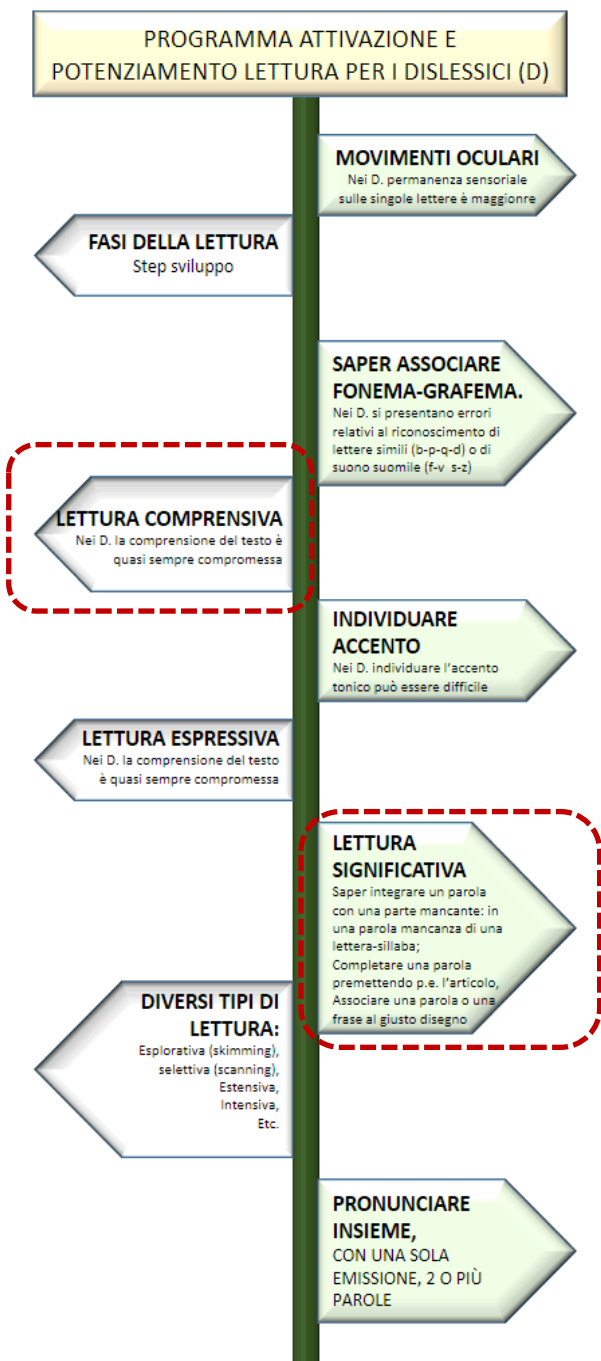

## Target di riferimento

Primaria	Metà prima
	Seconda
	Alunni con DSA
	Alunni con difficoltà lettura

Questi esercizi fanno parte del piano di potenziamento, recupero e attivazione della lettura per alunni della scuola primaria.

Possono essere utilizzati sia per potenziare la lettura negli alunni senza specifiche problematiche, sia per alunni con difficoltà di lettura.

Alla base del potenziamento non c'è «la quantità», una ripetizione continua di esercizi, ma la qualità: occorre che l'alunno impari a riflettere su quel che fa, e quindi a riflettere su quello che legge e come lo legge. Questo processo si chiama processo di metacognizione.

La fretta e l'eccessivo carico di lavoro producono effetti distrattori sull'apprendimento di qualunque alunno e in particolare sugli alunni con problematiche scolastiche.

**LETTURA SILLABE.** Leggere articolando bene e mantenendo un ritmo e veocità definita.

È anche inserita una combinazione di sillabe che forma una parola di senso compiuto.

Dopo una prima lettura dove non si fa notare la parola con senso compiuto (se anche la nota il bambino), dire: «Tra le sillabe che hai letto ce ne sono alcune che formano una parola che ha un preciso significato. Lei sai trovare?»

Appena le trovi le unisci con una freccia.

NOTA. Fare sempre una doppia lettura dalla singola sillaba a sinistra formare la bisillaba con tutte le sillabe a destra di questa, poi il contrario leggere ogni sillaba a destra unendola all sola sillaba a sinistra. Si avrà:

Fase 1: BA-GO / BA-LA / BA-CIO Fase 2: GO-BA / LA-BA / CIO-BA.

<b>BA</b>	<b>GO</b>
	<b>LA</b>
	<b>CIO</b>

<b>BU</b>	<b>TE</b>
	<b>SA</b>
	<b>CA</b>

<b>BI</b>	<b>ZA</b>
	<b>VE</b>
	<b>RO</b>

<b>BE</b>	<b>FA</b>
	<b>SU</b>
	<b>VE</b>

<b>BO</b>	<b>LA</b>
	<b>DA</b>
	<b>LO</b>

<b>BI</b>	<b>SO</b>
	<b>FA</b>
	<b>LE</b>

<b>BA</b>	<b>ZO</b>
	<b>SI</b>
	<b>RO</b>

<b>BU</b>	<b>LI</b>
	<b>FA</b>
	<b>E</b>

<b>BE</b>	<b>GHE</b>
	<b>NE</b>
	<b>ZA</b>

<b>BO</b>	<b>SGRA</b>
	<b>A</b>
	<b>SFRA</b>

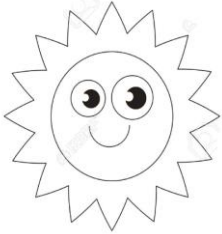
PA		RE
LE		SA
SO		

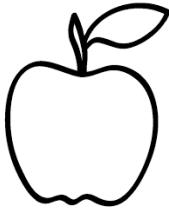
TE		STA
ME		FRA
LA		

O		SO
VA		GO
U		

NA		VE
TI		NO
NO		

TI		STA
CA		TRA
SA		

LU		MA
LI		PO
NA		

VE		SFA
TO		MI
MO		

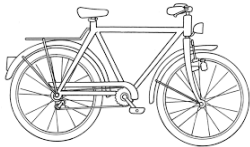
BU		CHE
CI		STA

GA		NE
SFRA		GHI
CA		

GU		SGRA
GE		SA
FO		

**LETTURA SILLABE.** Leggere articolando bene e mantenendo un ritmo e velocità definita.

È anche inserita una combinazione di sillabe che forma una parola di senso compiuto.

Dopo una prima lettura dove non si fa notare la parola con senso compiuto (se anche la nota il bambino), dire: «Tra le sillabe che hai letto ce ne sono alcune che formano una parola che ha un preciso significato. Lei sai trovare?»

Appena le trovi le unisci con una freccia. NOTA: sempre doppia lettura.

<b>CO</b>	<b>GO</b>
	<b>LA</b>
	<b>MO</b>

<b>CU</b>	<b>TE</b>
	<b>SA</b>
	<b>CA</b>

<b>CHI</b>	<b>ZA</b>
	<b>VE</b>
	<b>LO</b>

<b>CHE</b>	<b>FA</b>
	<b>SU</b>
	<b>LE</b>

<b>CA</b>	<b>LA</b>
	<b>DA</b>
	<b>SA</b>

<b>CO</b>	<b>ZO</b>
	<b>FA</b>
	<b>SA</b>

<b>CHE</b>	<b>ZO</b>
	<b>SI</b>
	<b>RO</b>

<b>CU</b>	<b>FI</b>
	<b>FA</b>
	<b>RA</b>

<b>CHI</b>	<b>GA</b>
	<b>BA</b>
	<b>ESA</b>

<b>CA</b>	<b>DE</b>
	<b>CHI</b>
	<b>GA</b>

NO		RE
LE		SA
	TA	

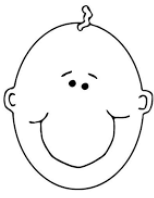
TE		STA
SO		FRA
	VI	

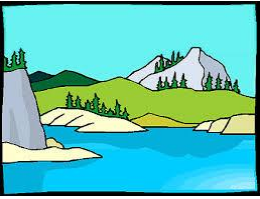
LA		SO
VA		VI
	GO	

NA		FA
TI		NO
	RO	

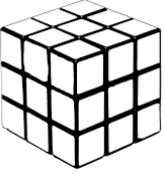
TI		STA
DO		TRA
	DA	

LU		MA
VE		PO
	NE	

VE		SFA
RA		MI
	PA	

BU		CHE
CI		RO
	SA	

GA		MA
SFRA		GHI
	LI	

SE		SGRA
GE		SA
	GA	



**LETTURA SILLABE.** Leggere articolando bene e mantenendo un ritmo e velocità definita.

È anche inserita una combinazione di sillabe che forma una parola di senso compiuto.

Dopo una prima lettura dove non si fa notare la parola con senso compiuto (se anche la nota il bambino), dire: «Tra le sillabe che hai letto ce ne sono alcune che formano una parola che ha un preciso significato. Lei sai trovare?»

Appena le trovi le unisci con una freccia. NOTA: fare sempre doppia lettura.

<b>CO</b>	<b>GO</b>
	<b>LA</b>
	<b>MO</b>

<b>CU</b>	<b>TE</b>
	<b>SA</b>
	<b>CA</b>

<b>DA</b>	<b>ZA</b>
	<b>VE</b>
	<b>DO</b>

<b>DE</b>	<b>FA</b>
	<b>SU</b>
	<b>A</b>

<b>DI</b>	<b>LA</b>
	<b>DA</b>
	<b>TO</b>

<b>DU</b>	<b>ZO</b>
	<b>CA</b>
	<b>SA</b>

<b>DO</b>	<b>ZO</b>
	<b>SI</b>
	<b>GHE</b>

<b>DA</b>	<b>FI</b>
	<b>FA</b>
	<b>MA</b>

<b>DI</b>	<b>GA</b>
	<b>BA</b>
	<b>ESA</b>

<b>DE</b>	<b>DE</b>
	<b>CHI</b>
	<b>GNO</b>

NO		RE
LU		SA
	PO	

LA		STA
SO		FRA
	NA	

LA		SO
CE		VI
	NO	

NA		FA
TI		TE
	VI	

TI		VI
DO		TRA
	NO	

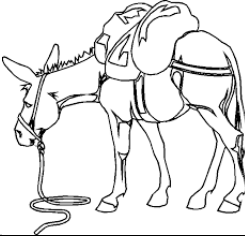
LU		MA
MU		PO
	LO	

VE		SFA
NI		MI
	DO	

BU		MA
CI		RO
	NO	

GA		MA
SFRA		SO
	NA	

SE		SGRA
GE		TO
	DI	



**LETTURA SILLABE.** Leggere articolando bene e mantenendo un ritmo e velocità definita.

È anche inserita una combinazione di sillabe che forma una parola di senso compiuto.

Dopo una prima lettura dove non si fa notare la parola con senso compiuto (se anche la nota il bambino), dire: «Tra le sillabe che hai letto ce ne sono alcune che formano una parola che ha un preciso significato. Lei sai trovare?»

Appena le trovi le unisci con una freccia. NOTA: fare sempre doppia lettura.

<b>CO</b>	<b>GO</b>
	<b>LA</b>
	<b>MO</b>

<b>CU</b>	<b>TE</b>
	<b>SA</b>
	<b>CA</b>

<b>DA</b>	<b>ZA</b>
	<b>VE</b>
	<b>DO</b>

<b>DE</b>	<b>FA</b>
	<b>SU</b>
	<b>A</b>

<b>DI</b>	<b>LA</b>
	<b>DA</b>
	<b>TO</b>

<b>DU</b>	<b>ZO</b>
	<b>CA</b>
	<b>SA</b>

<b>DO</b>	<b>ZO</b>
	<b>SI</b>
	<b>GHE</b>

<b>DA</b>	<b>FI</b>
	<b>FA</b>
	<b>MA</b>

<b>DI</b>	<b>GA</b>
	<b>BA</b>
	<b>ESA</b>

<b>DE</b>	<b>DE</b>
	<b>CHI</b>
	<b>GNO</b>

**LETTURA SILLABE E LORO FUSIONE, SEGMENTAZIONE.** Leggere prima tutte le sillabe, **POI LEGGERE LE DUE SILLABE NEL RIQUADRO GRIGIO** controllare se le due sillabe formano la parola giusta del disegno, se sbagliata cancellare con un x la sillaba o sillabe sbagliate e cercare le sillabe giuste da sostituire. Riscrivere sotto la parola giusta.

NO		RE
LU		SA
	TA	PO

LA		STA
SO		FRA
	TA	NA

NA		FA
TI		TE
	VI	LE

LA		SO
CE		VI
	NO	TA

TI		VI
DO		TRA
	TI	NO

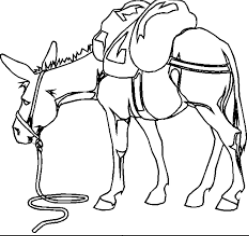
LU		MA
MU		LO
	NU	DO

GA		MA
SFRA		SO
	NA	VE

LU		MA
MU		TO
	DI	VA

**LETTURA SILLABE.** Leggere articolando bene e mantenendo un ritmo e velocità definita.

È anche inserita una combinazione di sillabe che forma una parola di senso compiuto.

Dopo una prima lettura dove non si fa notare la parola con senso compiuto (se anche la nota il bambino), dire: «Tra le sillabe che hai letto ce ne sono alcune che formano una parola che ha un preciso significato. Lei sai trovare?»

Appena le trovi le unisci con una freccia. **NOTA.** Fare sempre doppia lettura.

<b>FRA</b>	<b>GO</b>
	<b>MA</b>
	<b>SE</b>

<b>FRE</b>	<b>NO</b>
	<b>SE</b>
	<b>CA</b>

<b>FRU</b>	<b>STA</b>
	<b>VE</b>
	<b>DO</b>

<b>FRI</b>	<b>FA</b>
	<b>SU</b>
	<b>GO</b>

<b>FRO</b>	<b>LA</b>
	<b>DE</b>
	<b>TO</b>

<b>FRA</b>	<b>ZO</b>
	<b>NA</b>
	<b>TE</b>

<b>FRI</b>	<b>ZO</b>
	<b>SBI</b>
	<b>GHE</b>

<b>FRO</b>	<b>FI</b>
	<b>FA</b>
	<b>NTE</b>

<b>FRU</b>	<b>GA</b>
	<b>BA</b>
	<b>SCIO</b>

<b>FRE</b>	<b>DE</b>
	<b>CHI</b>
	<b>TTA</b>

**LETTURA SILLABE E LORO FUSIONE, SEGMENTAZIONE.** Leggere prima tutte le sillabe, **POI LEGGERE LE DUE SILLABE NEL RIQUADRO GRIGIO** controllare se le due sillabe formano la parola giusta del disegno, se sbagliata cancellare con un x la sillaba o sillabe sbagliate e cercare le sillabe giuste da sostituire. Riscrivere sotto la parola giusta.

BU		MA
CI		RO
	SA NO	

VE		SFA
NI		MI
	VE DO	

NA		FA
TI		RE
	MO LE	

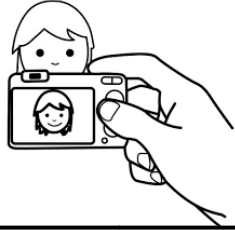
LA		SO
FO		VI
	NO TO	

TI		PA
DO		TRA
	TE LA	

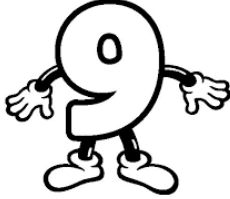
LU		MA
MU		VE
	NO DO	

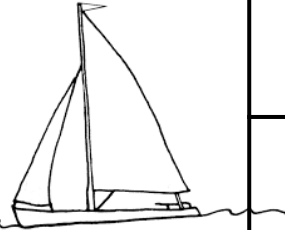
GA		MA
SFRA		VE
	MU LA	

LU		RE
MU		TO
	FU MO	

**LETTURA SILLABE.** Leggere articolando bene e mantenendo un ritmo e velocità definita.

È anche inserita una combinazione di sillabe che forma una parola di senso compiuto.

Dopo una prima lettura dove non si fa notare la parola con senso compiuto (se anche la nota il bambino), dire: «Tra le sillabe che hai letto ce ne sono alcune che formano una parola che ha un preciso significato. Lei sai trovare?»

Appena le trovi le unisci con una freccia. **NOTA.** Fare sempre doppia lettura.

<b>GRA</b>	<b>GO</b>
	<b>MA</b>
	<b>SSO</b>

<b>GRE</b>	<b>NO</b>
	<b>CO</b>
	<b>CA</b>

<b>GRU</b>	<b>STA</b>
	<b>GNO</b>
	<b>DO</b>

<b>GRI</b>	<b>DO</b>
	<b>SU</b>
	<b>GO</b>

<b>GRO</b>	<b>LA</b>
	<b>DE</b>
	<b>TTA</b>

<b>GRA</b>	<b>ZO</b>
	<b>NA</b>
	<b>TE</b>

<b>GRI</b>	<b>ZO</b>
	<b>SBI</b>
	<b>GIO</b>

<b>GRO</b>	<b>FI</b>
	<b>FA</b>
	<b>NTE</b>

<b>GRU</b>	<b>GA</b>
	<b>BA</b>
	<b>MO</b>

<b>GRE</b>	<b>DE</b>
	<b>CHI</b>
	<b>VE</b>

**LETTURA SILLABE E LORO FUSIONE, SEGMENTAZIONE.** Leggere prima tutte le sillabe, **POI LEGGERE LE DUE SILLABE NEL RIQUADRO GRIGIO** controllare se le due sillabe formano la parola giusta del disegno, se sbagliata cancellare con un x la sillaba o sillabe sbagliate e cercare le sillabe giuste da sostituire. Riscrivere sotto la parola giusta.

BU		MA
CI		RO
	MU TO	

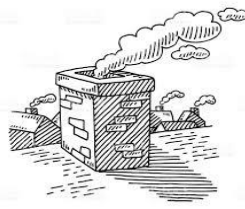
VE		SFA
NI		MO
	FU NE	

NA		CO
TI		RE
	FI LA	

LA		SO
PA		VI
	NO NE	

TI		CA
DO		TRA
	FO TO	

LU		MA
MU		TA
	FA RO	

GA		MA
SA		VE
	MU LE	

LU		RE
MU		NO
	PI LA	



**LETTURA SILLABE.** Leggere articolando bene e mantenendo un ritmo e velocità definita.

È anche inserita una combinazione di sillabe che forma una parola di senso compiuto.

Dopo una prima lettura dove non si fa notare la parola con senso compiuto (se anche la nota il bambino), dire: «Tra le sillabe che hai letto ce ne sono alcune che formano una parola che ha un preciso significato. Lei sai trovare?»

Appena le trovi le unisci con una freccia. **NOTA.** Fare sempre doppia lettura.

<b>TRA</b>	<b>GO</b>
	<b>MA</b>
	<b>TE</b>

<b>TRE</b>	<b>NO</b>
	<b>NO</b>
	<b>CA</b>

<b>TRU</b>	<b>STA</b>
	<b>LLO</b>
	<b>DO</b>

<b>TRI</b>	<b>DO</b>
	<b>BÙ</b>
	<b>GO</b>

<b>TRO</b>	<b>LA</b>
	<b>DE</b>
	<b>NO</b>

<b>TRA</b>	<b>ZO</b>
	<b>NA</b>
	<b>VE</b>

<b>TRI</b>	<b>ZO</b>
	<b>LLI</b>
	<b>GIO</b>

<b>TRO</b>	<b>FI</b>
	<b>TA</b>
	<b>NTE</b>

<b>TRU</b>	<b>GA</b>
	<b>CCO</b>
	<b>MO</b>

<b>TRE</b>	<b>DE</b>
	<b>NTA</b>
	<b>VE</b>

**LETTURA SILLABE E LORO FUSIONE, SEGMENTAZIONE.** Leggere prima tutte le sillabe, **POI LEGGERE LE DUE SILLABE NEL RIQUADRO GRIGIO** controllare se le due sillabe formano la parola giusta del disegno, se sbagliata cancellare con un x la sillaba o sillabe sbagliate e cercare le sillabe giuste da sostituire. Riscrivere sotto la parola giusta.

BU		MA
CI		RA
	MI MO	

VE		SFA
NI		GO
	MA NO	

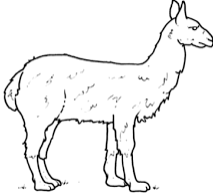
NA		MA
TI		RE
	LA LA	

LA		NO
PA		VI
	CO VO	

TI		CA
RA		TRA
	TA NA	

LU		MA
RI		TA
	DO GA	

GA		MA
SA		PO
	TO RO	

LU		TO
MU		NO
	PE RO	

**LETTURA SILLABE.** Leggere articolando bene e mantenendo un ritmo e veocità definita.

È anche inserita una combinazione di sillabe cha forma una parola di senso compiuto.

Dopo una prima lettura dove non si fa notare la parola con senso compiut (se anche la nota il bambino), dire: «Tra le sillabe che hai letto ce ne sono alcune che formano una parola che ha un preciso significato. Lei sai trovare?

Appena le trovi le unisci con una freccia. Nota: FARE SEMPRE DOPPIA LETTURA.

<b>PRA</b>	<b>GO</b>
	<b>TO</b>
	<b>TE</b>

<b>PRE</b>	<b>NO</b>
	<b>TE</b>
	<b>CA</b>

<b>PRU</b>	<b>STA</b>
	<b>A</b>
	<b>DO</b>

<b>PRI</b>	<b>DO</b>
	<b>DO</b>
	<b>MA</b>

<b>PRO</b>	<b>LA</b>
	<b>VA</b>
	<b>NO</b>

<b>PRA</b>	<b>NZO</b>
	<b>NA</b>
	<b>VE</b>

<b>PRI</b>	<b>ZO</b>
	<b>SMA</b>
	<b>GIO</b>

<b>PRO</b>	<b>FI</b>
	<b>TA</b>
	<b>LE</b>

<b>PRU</b>	<b>GA</b>
	<b>GNA</b>
	<b>MO</b>

<b>PRE</b>	<b>DE</b>
	<b>STO</b>
	<b>VE</b>

**LETTURA SILLABE.** La ruota propone le parole. Il bambino le deve numerare; poi deve cercare di scoprire le sillabe che formano ogni singola parola. Quando ha scoperta la prima le numera con 1,2 e3. Le pronuncia prima separata sillabando poi pronuncia la parola intera. Infine le scrive le singole sillabe nella casella per formare la parola. Si fa lo stesso con la seconda parola, i numeri saranno questa volta 4,5 e 6.

**RUOTA DELLE PAROLE**

LU	MA	CA
----	----	----

DI	VA	NO
----	----	----

**RUOTA DELLE PAROLE**

--	--	--

--	--	--

**LETTURA SILLABE.** La ruota delle parole. La ruota propone due figure. Il bambino le deve denominare; poi deve cercare di scoprire le sillabe che formano ogni singola parola. Quando ha scoperta la prima le numera con 1,2 e3. Le pronuncia prima separata sillabando poi pronuncia la parola intera. Infine le scrive le singole sillabe nella casella per formare la parola. Si fa lo stesso con la seconda parola, i numeri saranno questa volta 4,5 e 6.

**RUOTA DELLE PAROLE**

MO NA SA NA MI BA

**RUOTA DELLE PAROLE**

MU PE LI RA MO PA

**LETTURA SILLABE.** La ruota delle parole. La ruota propone due figure. Il bambino le deve denominare; poi deve cercare di scoprire le sillabe che formano ogni singola parola. Quando ha scoperta la prima le numera con 1,2 e3. Le pronuncia prima separata sillabando poi pronuncia la parola intera. Infine le scrive le singole sillabe nella casella per formare la parola. Si fa lo stesso con la seconda parola, i numeri saranno questa volta 4,5 e 6.

**RUOTA DELLE PAROLE**

PE RO CO TA CA RA

**RUOTA DELLE PAROLE**

NA FOR TE CI BI CA



**LETTURA SILLABE. PIOGGIA DI PAROLE.** Cadono gocce di sillabe, con le diverse gocce si possono formare due parole. I disegni sono tre, uno non c'entra, è un distrattore. Individuate le sillabe vanno prima numerate e poi collegate al rispettivo disegno. Usare due colori diversi.

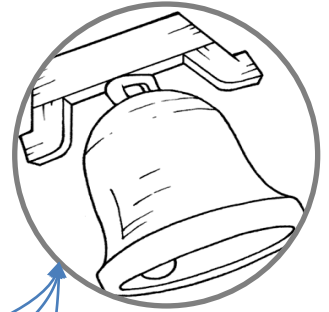

Esempio

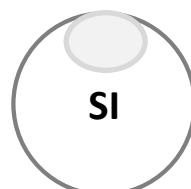
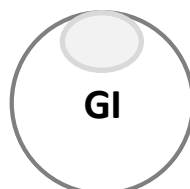
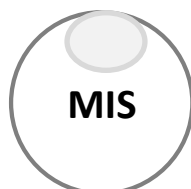
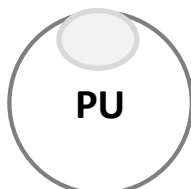
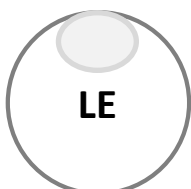
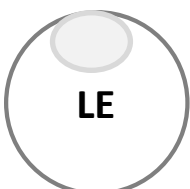
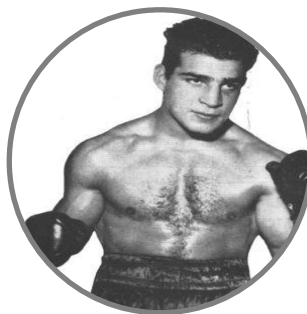
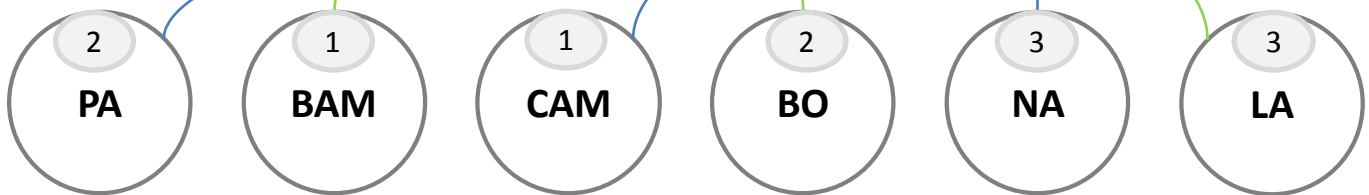

**LETTURA SILLABE.** La ruota delle parole. La ruota propone due figure. Il bambino le deve denominare; poi deve cercare di scoprire le sillabe che formano ogni singola parola. Quando ha scoperta la prima le numera con 1,2 e3. Le pronuncia prima separata sillabando poi pronuncia la parola intera. Infine le scrive le singole sillabe nella casella per formare la parola. Si fa lo stesso con la seconda parola, i numeri saranno questa volta 4,5 e 6.

**RUOTA DELLE PAROLE**

SE

TI

TA

DA

NO

MA

**RUOTA DELLE PAROLE**

PEN

VA

TO

GNA

LA

LA

**LETTURA SILLABE. PIOGGIA DI PAROLE.** Cadono gocce di sillabe, con le diverse gocce si possono formare due parole. I disegni sono tre, uno non c'entra, è un distrattore. Individuate le sillabe vanno prima numerate e poi collegate al rispettivo disegno. Usare due colori diversi.

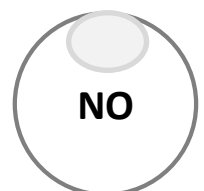
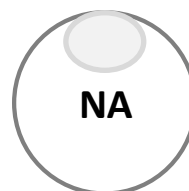
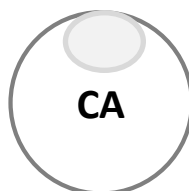
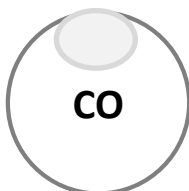
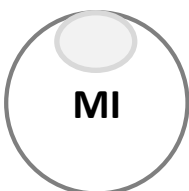
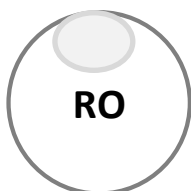
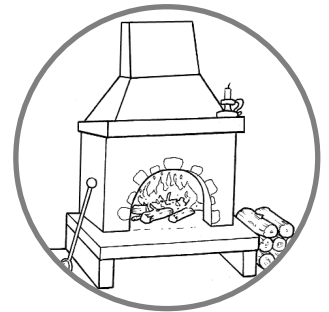
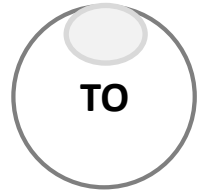
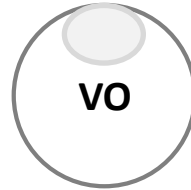
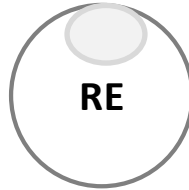
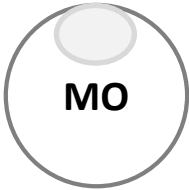
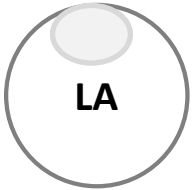

**LETTURA SILLABE.** La ruota delle parole. La ruota propone due figure. Il bambino le deve denominare; poi deve cercare di scoprire le sillabe che formano ogni singola parola. Quando ha scoperta la prima le numera con 1,2 e3. Le pronuncia prima separata sillabando poi pronuncia la parola intera. Infine le scrive le singole sillabe nella casella per formare la parola. Si fa lo stesso con la seconda parola, i numeri saranno questa volta 4,5 e 6.

**RUOTA DELLE PAROLE**

ME CA LA CIA MI SA

**RUOTA DELLE PAROLE**

TA CAN NE LA MO DE

**LETTURA SILLABE. PIOGGIA DI PAROLE.** Cadono gocce di sillabe, con le diverse gocce si possono formare due parole. I disegni sono tre, uno non c'entra, è un distrattore. Individuate le sillabe vanno prima numerate e poi collegate al rispettivo disegno. Usare due colori diversi.



VO

LI

PA

GE

NE

VA

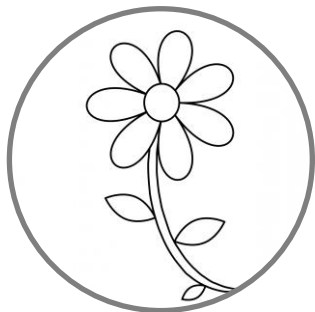

LE



LI

BA



PO

NA

PO

				
<b>RETE</b>		<b>RANA</b>		<b>CASA</b>

				
<b>FORBICI</b>		<b>OROLOGIO</b>		<b>ZAINO</b>

				
<b>LIBRO</b>		<b>COMPUTER</b>		<b>COLORI</b>

				
<b>TRENO</b>		<b>DALLONE</b>		<b>ORSO</b>



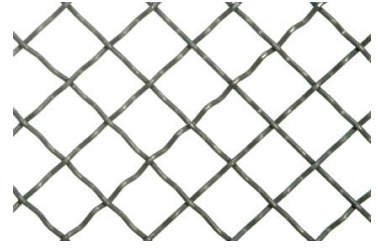
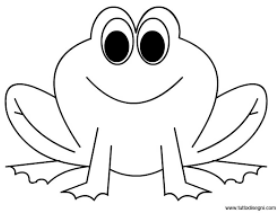

TRENO
7AINO
7EBBINO
LIBRO
BETE
CASA
COSE
RANA
ORSO
DARATA
DALLONE
COMPIITER
OROLOGIO
COLORI
CONTARE
FORBICI



**LETTURA SILLABE.** Leggere articolando bene e mantenendo un ritmo e velocità definita.

È anche inserita una combinazione di sillabe che forma una parola di senso compiuto.

Dopo una prima lettura dove non si fa notare la parola con senso compiuto (se anche la nota il bambino), dire: «Tra le sillabe che hai letto ce ne sono alcune che formano una parola che ha un preciso significato. Lei sai trovare?»

Appena le trovi le unisci con una freccia. **NOTA :** fare sempre doppia lettura.

<b>FRA</b>	<b>GO</b>
	<b>MA</b>
	<b>TE</b>

<b>PRE</b>	<b>NO</b>
	<b>TE</b>
	<b>CA</b>

<b>TRA</b>	<b>STA</b>
	<b>VE</b>
	<b>DO</b>

<b>TRA</b>	<b>DO</b>
	<b>M</b>
	<b>GO</b>

<b>GRA</b>	<b>LA</b>
	<b>DE</b>
	<b>TO</b>

<b>PRA</b>	<b>ZO</b>
	<b>NA</b>
	<b>TO</b>

<b>TRE</b>	<b>ZO</b>
	<b>LLI</b>
	<b>NO</b>

<b>FRE</b>	<b>FI</b>
	<b>TA</b>
	<b>NO</b>

<b>GRE</b>	<b>GA</b>
	<b>TA</b>
	<b>MO</b>

<b>GRU</b>	<b>DE</b>
	<b>MO</b>
	<b>VE</b>

**LETTURA SILLABE E LORO FUSIONE, SEGMENTAZIONE.** Leggere prima tutte le sillabe, **POI LEGGERE LE DUE SILLABE NEL RIQUADRO GRIGIO** controllare se le due sillabe formano la parola giusta del disegno, se sbagliata cancellare con un x la sillaba o sillabe sbagliate e cercare le sillabe giuste da sostituire. Riscrivere sotto la parola giusta.

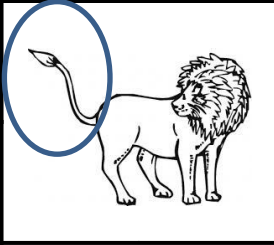
BU		DA
CO		RA
	CA RO	

VE		SFA
NI		RA
	MA GNO	

NA		MA
TI		VE
	PE RA	

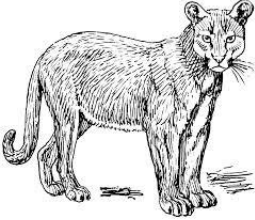
LA		NO
PU		VI
	MA MA	

TI		LA
RA		TRA
	TE CA	

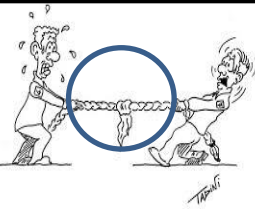
LU		MA
RI		NE
	FU GA	

GA		MA
RE		PO
	TO RO	

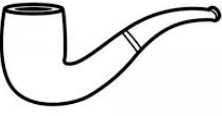
LU		PA
MU		NO
	PI RO	

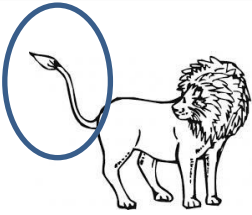
<b>CODI</b>		<b>ODI</b>
<b>CODA</b>		<b>NODA</b>

<b>REGNO</b>		<b>GNORA</b>
<b>PEGNO</b>		<b>RAGNO</b>

<b>NAIA</b>		<b>NAVE</b>
<b>NOVI</b>		<b>VANE</b>

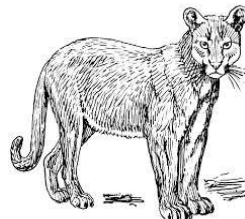
<b>PULA</b>		<b>MUPA</b>
<b>PUTA</b>		<b>PUMA</b>

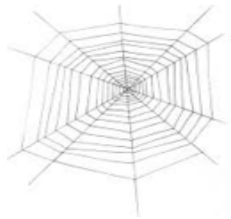
<b>META</b>		<b>TELA</b>
<b>TEMA</b>		<b>LATA</b>

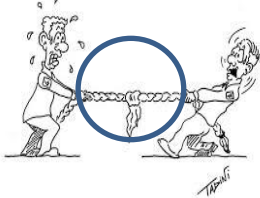
<b>LUNA</b>		<b>FUNE</b>
<b>FUTA</b>		<b>NEFU</b>

<b>MORE</b>		<b>MARE</b>
<b>MIRA</b>		<b>MURO</b>

<b>PIO</b>		<b>PAPI</b>
<b>PINA</b>		<b>PIPA</b>

<b>MANI</b>		<b>DITA</b>
<b>MINA</b>		<b>MANO</b>

<b>NEVE</b>		<b>ODO</b>
<b>NIDO</b>		<b>DIDO</b>

<b>RENNA</b>		<b>RANA</b>
<b>RENO</b>		<b>RAMO</b>

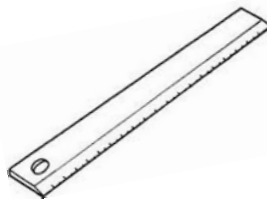
<b>RIVA</b>		<b>GARE</b>
<b>RIGA</b>		<b>REMA</b>

MARE		MIRA
ORE		MORE

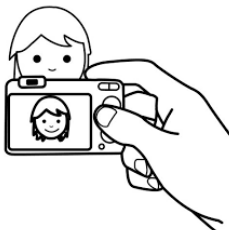
OTO		MOTO
FOTO		TOFO

RAMO		ERMO
REMO		MERO

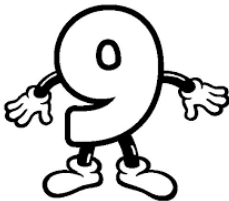
NAVE		VENO
NOVE		NEVE

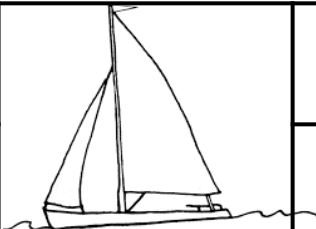
VEIA		LAIA
VELLA		VELA

AMO		REMO
RAMO		RIMA

MEGA		MATO
AGO		MAGO

CANE		NACO
CANO		NUDO

TIRA		TORO
TARA		TURA

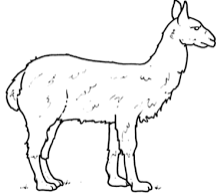
AMA		MALE
AMO		LAMA

RETE		REMA
FOGLIA		RAMO

TOA		TOPO
ATO		TIPO

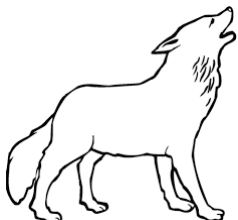
<b>LUO</b>		<b>LAPO</b>
<b>LUNA</b>		<b>LUPO</b>

<b>LENA</b>		<b>NELA</b>
<b>LANA</b>		<b>NALE</b>

<b>VIA</b>		<b>VITE</b>
<b>VATE</b>		<b>VITA</b>

<b>NOE</b>		<b>CENA</b>
<b>OCE</b>		<b>NOCE</b>

<b>UVA</b>		<b>INO</b>
<b>VINO</b>		<b>FINO</b>

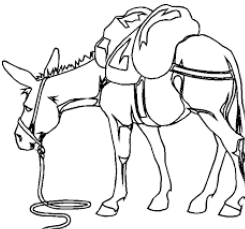
<b>ULO</b>		<b>MUTO</b>
<b>PULA</b>		<b>MULO</b>

<b>OSO</b>		<b>NASO</b>
<b>OSA</b>		<b>BOSA</b>

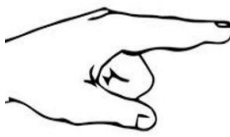
<b>DATO</b>		<b>ATO</b>
<b>DITO</b>		<b>ITO</b>

<b>URRà</b>		<b>ROSSO</b>
<b>MUTO</b>		<b>MURO</b>

<b>FIA</b>		<b>FINA</b>
<b>FETA</b>		<b>FICO</b>

<b>ANE</b>		<b>NIPA</b>
<b>IANE</b>		<b>PANE</b>

<b>OCA</b>		<b>LOCA</b>
<b>BROCA</b>		<b>FOCA</b>

<b>NAVE</b>		<b>NOTA</b>
<b>NOVE</b>		<b>NOME</b>

<b>VASO</b>		<b>ESO</b>
<b>VISO</b>		<b>FUSO</b>

<b>ARO</b>		<b>FERO</b>
<b>MARO</b>		<b>FARO</b>

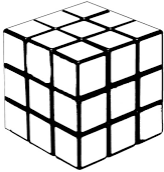
<b>DUE</b>		<b>DODO</b>
<b>DAI</b>		<b>DADO</b>

<b>RIPA</b>		<b>REPA</b>
<b>RUPE</b>		<b>RAPA</b>

<b>OSA</b>		<b>COSA</b>
<b>ROSA</b>		<b>FOSA</b>

<b>IMA</b>		<b>LIMA</b>
<b>TIMA</b>		<b>MALI</b>

<b>SEA</b>		<b>SEME</b>
<b>SETA</b>		<b>SEGA</b>

<b>FURBO</b>		<b>MUFO</b>
<b>FUMO</b>		<b>FUA</b>

<b>FAME</b>		<b>FUCO</b>
<b>FATA</b>		<b>FELLA</b>

<b>SOLO</b>		<b>SUMA</b>
<b>SALE</b>		<b>SULLO</b>

<b>PENA</b>		<b>IPPO</b>
<b>PONI</b>		<b>PINO</b>



**LETTURA PAROLE. IL PERCORSO DELLE SILLABE.** Leggi prima le sillabe seguendo il percorso delle frecce, dopo scopri le sillabe che formano le parole dei due disegni unendole con le frecce. Poi si possono anche scrivere le parole sotto i rispettivi disegni.

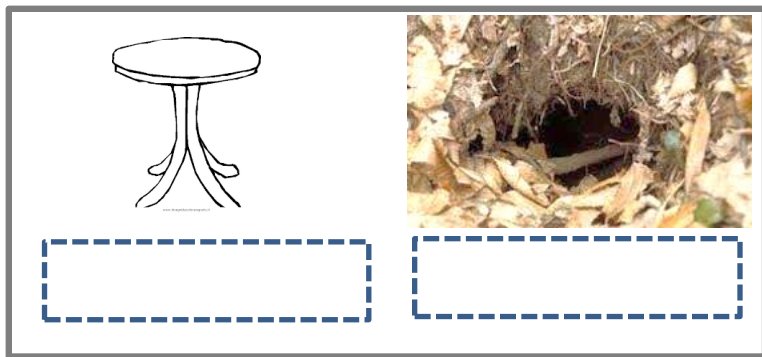
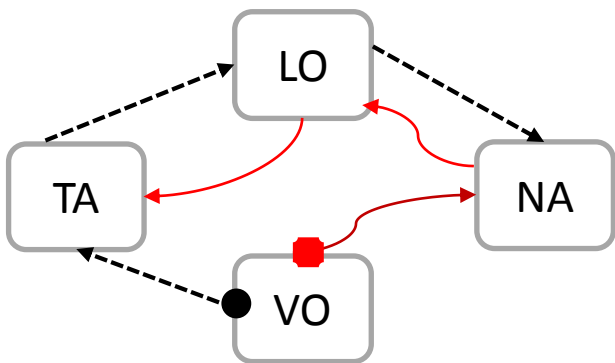
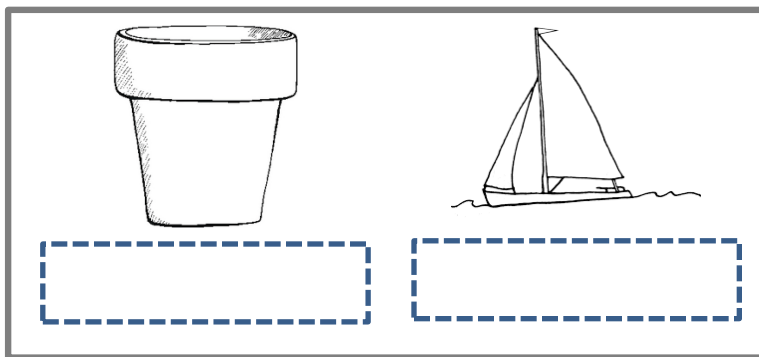
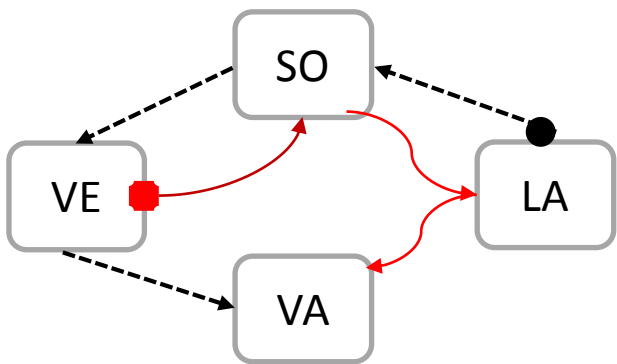
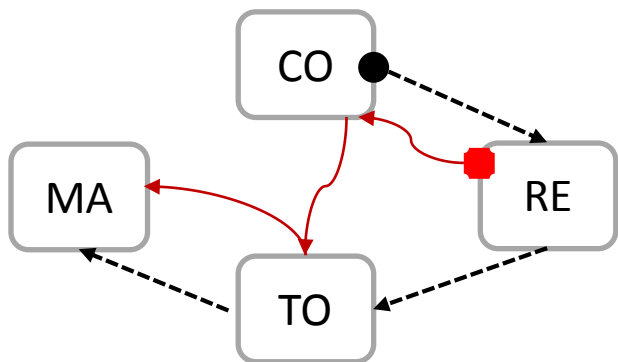
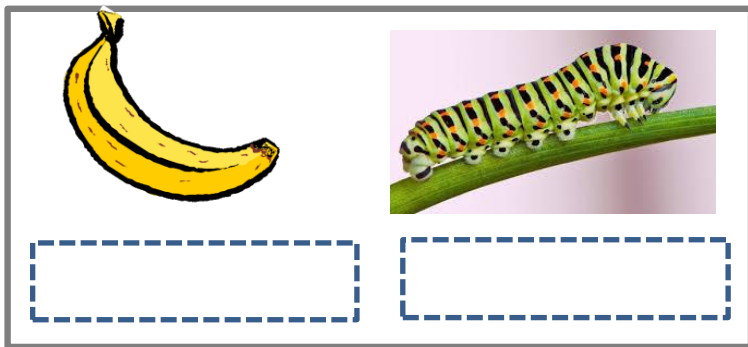
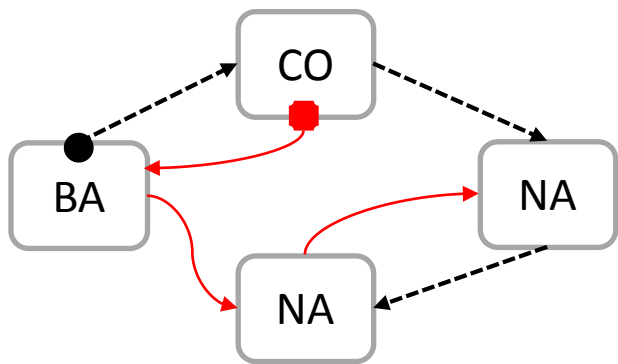



**LETTURA PAROLE. IL PERCORSO DELLE SILLABE.** Leggi prima le sillabe seguendo il percorso delle frecce, dopo scopri le sillabe che formano le parole dei due disegni unendole con le frecce. Poi si possono anche scrivere le parole sotto i rispettivi disegni.

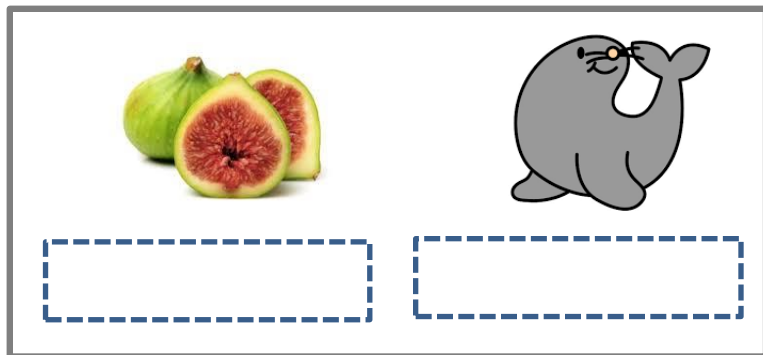
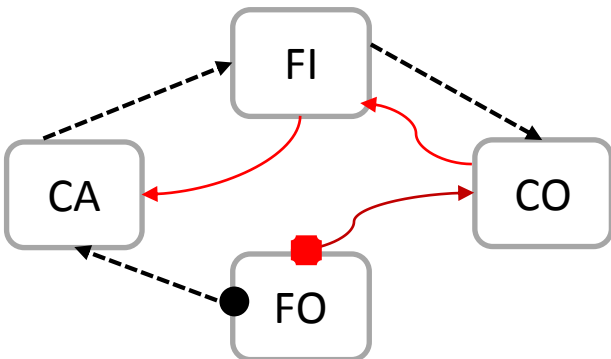
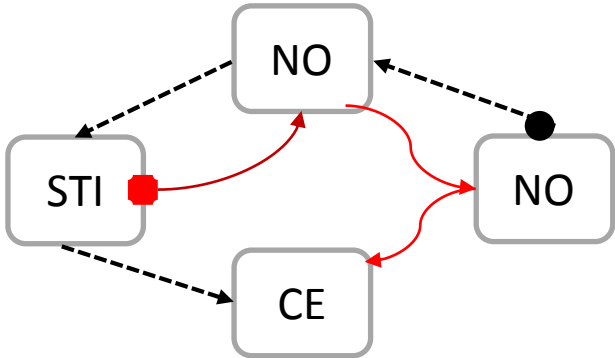
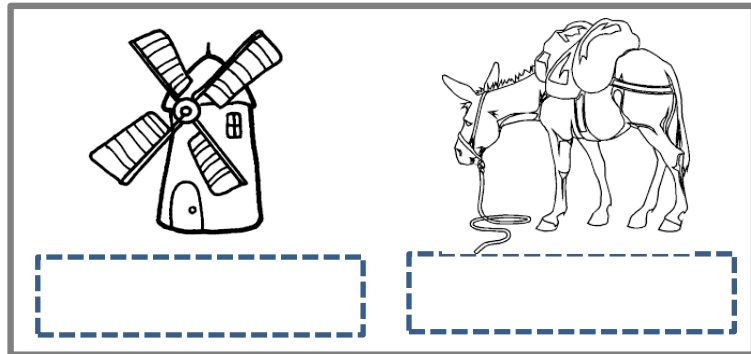
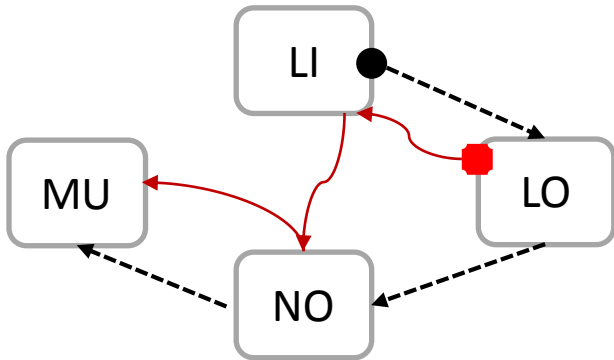
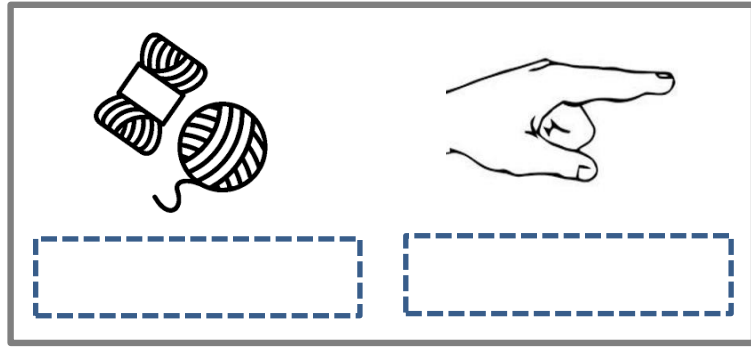
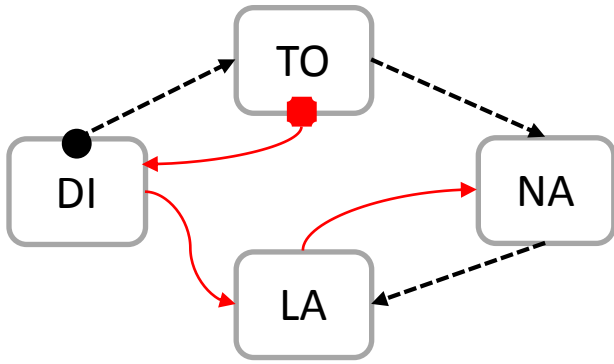



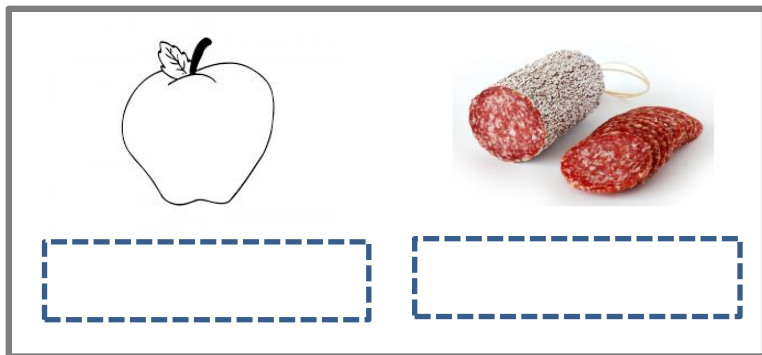
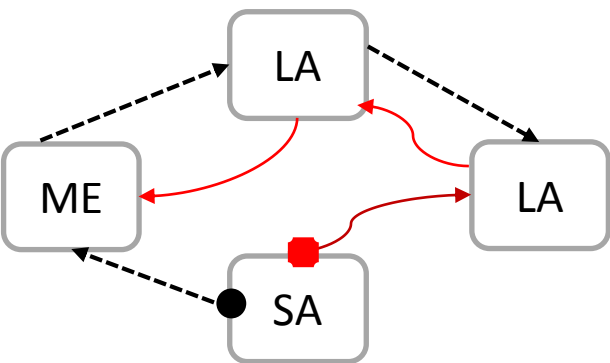
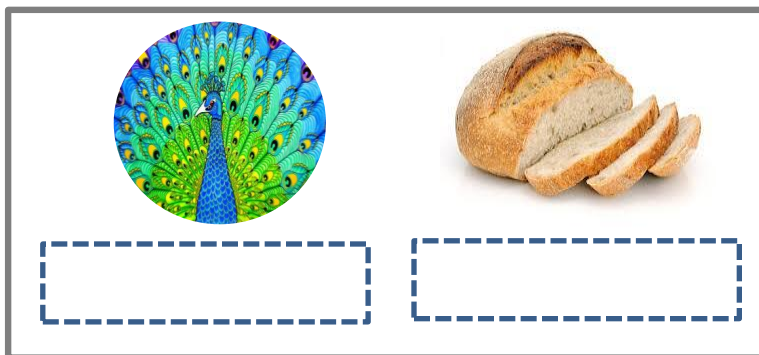
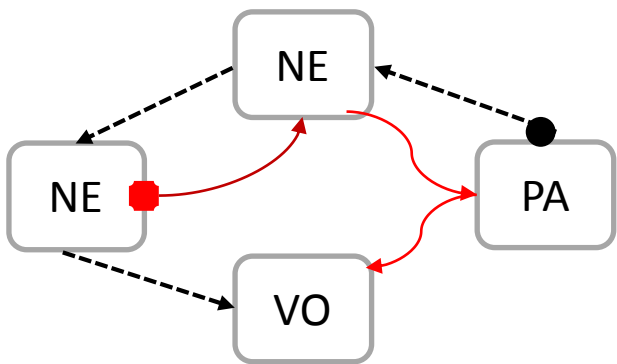
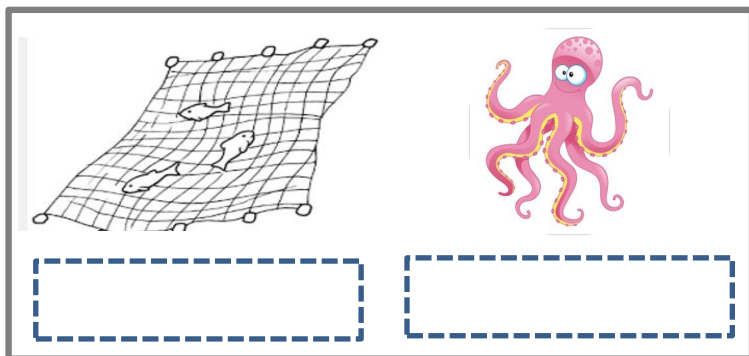
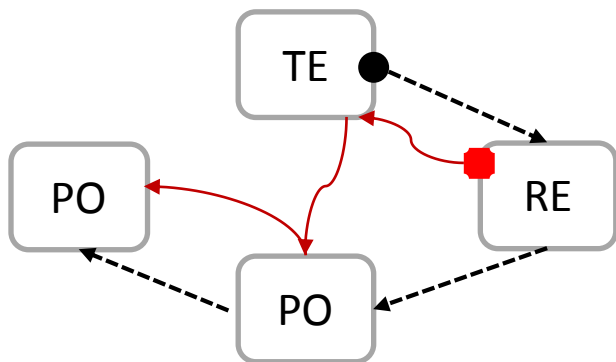
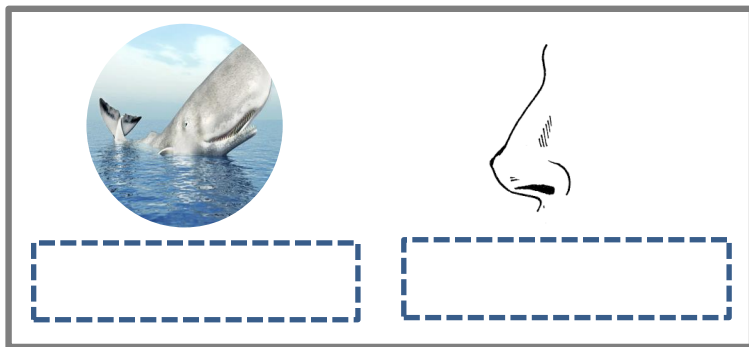
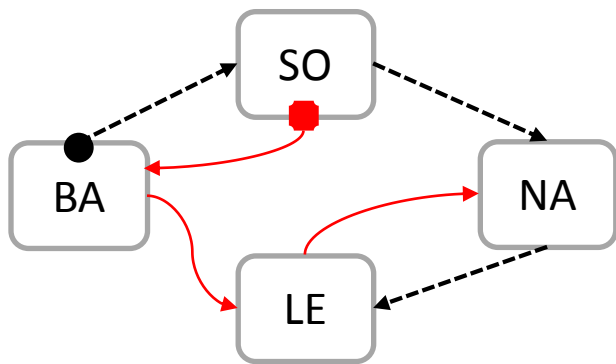



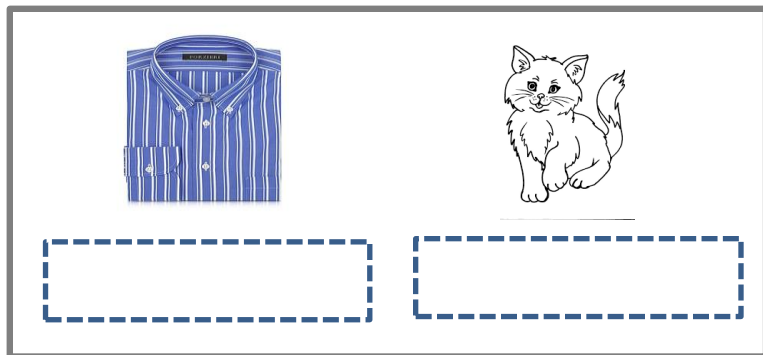
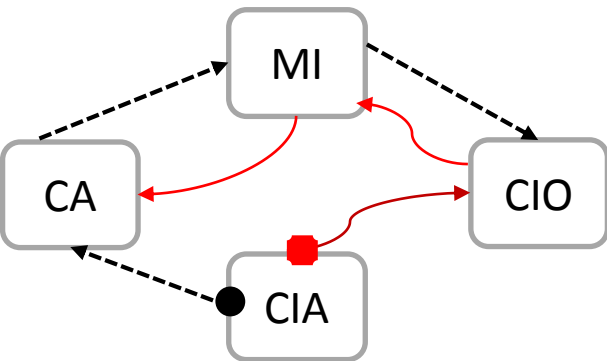
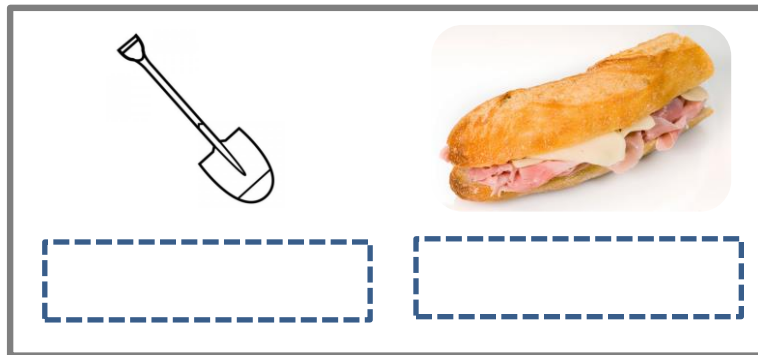
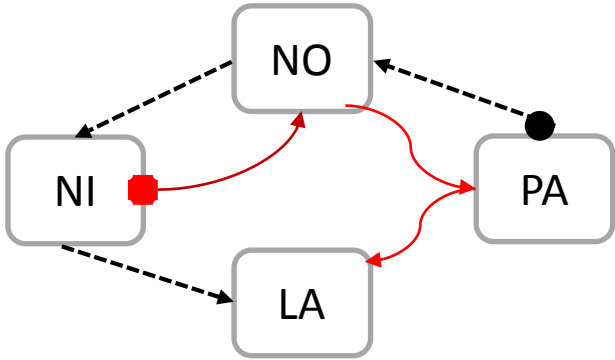
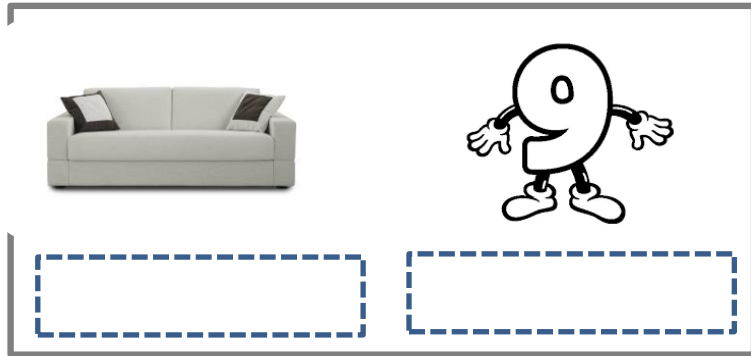
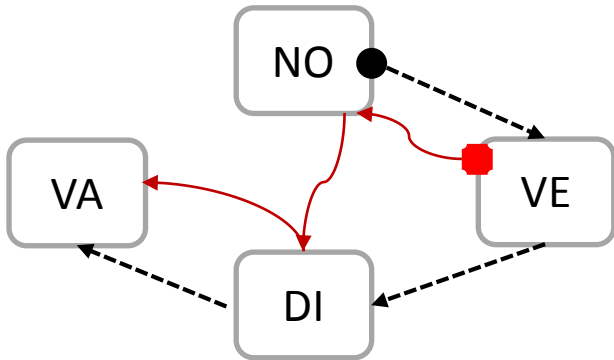
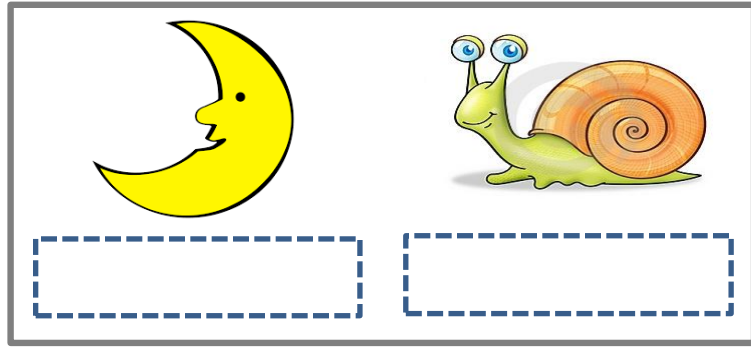
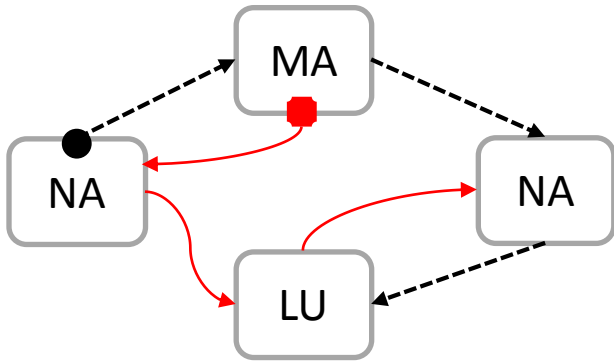





**LETTURA PAROLE. IL PERCORSO DELLE SILLABE.** Leggi prima le sillabe seguendo il percorso delle frecce, dopo scopri le sillabe che formano le parole dei due disegni unendole con le frecce. Poi si possono anche scrivere le parole sotto i rispettivi disegni.











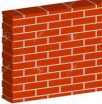

**LETTURA PAROLE. IL PERCORSO DELLE SILLABE.** Leggi prima le sillabe seguendo il percorso delle frecce, dopo scopri le sillabe che formano le parole dei due disegni unendole con le frecce. Poi si possono anche scrivere le parole sotto i rispettivi disegni.





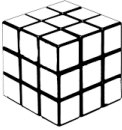









	NE			PA
NA				NO
	VE			VE
LU				VI
	NA			SO
	CA			LA

	NO			PA
FA				CA
	NE			ME
PA				LU
	MA			PI
	TA			SA

	RO			PO
FI				NO
	CA			RA
	CHI			TO
MU				NA
	FOA			CO

	TE				RA
CA				LA	NA
	NE				
DA				MO	RE
	DO				
	VI				GNO

	NO				NO
RA				LA	SA
	CIO				
MI				RO	VI
	PI				
	MO				MA

	RO				MA
NO				FU	PU
	GO				
TO				LI	MO
	TA				
	MA				MA



*continua  
con le  
schede  
n. 3*